

General Description

OST50N65HEV2F uses advanced Oriental-Semi's patented Trident-Gate Bipolar Transistor (TGBT™) technology to provide extremely low $V_{CE(sat)}$, low gate charge, and excellent switching performance. This device is suitable for mid to high range switching frequency converters.

Features

- Advanced TGBT™ technology
- Excellent conduction and switching loss
- Excellent stability and uniformity



Applications

- Induction converters
- Uninterruptible power supplies

Key Performance Parameters

| Parameter | Value | Unit |
|------------------------------------|-------|------|
| $V_{CES, min}$ @ 25 °C | 650 | V |
| Maximum junction temperature | 175 | °C |
| $I_C, pulse$ | 200 | A |
| $V_{CE(sat), typ}$ @ $V_{GE}=15$ V | 1.55 | V |
| Q_g | 112 | nC |

Marking Information

| Product Name | Package | Marking |
|---------------|---------|--------------|
| OST50N65HEV2F | TO247 | OST50N65HEV2 |

Package & Pin Information

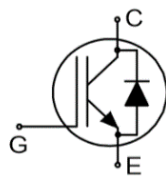

Absolute Maximum Ratings at $T_{vj}=25\text{ °C}$ unless otherwise noted

| Parameter | Symbol | Value | Unit |
|---|-------------------|------------|------|
| Collector emitter voltage | V_{CES} | 650 | V |
| Gate emitter voltage | V_{GES} | ± 20 | V |
| Transient gate emitter voltage, $T_P \leq 10\ \mu s$, $D < 0.01$ | | ± 30 | V |
| Continuous collector current ¹⁾ , $T_C=25\text{ °C}$ | I_C | 80 | A |
| Continuous collector current ¹⁾ , $T_C=100\text{ °C}$ | | 50 | A |
| Pulsed collector current ²⁾ , $T_C=25\text{ °C}$ | $I_{C, pulse}$ | 200 | A |
| Diode forward current ¹⁾ , $T_C=25\text{ °C}$ | I_F | 80 | A |
| Diode forward current ¹⁾ , $T_C=100\text{ °C}$ | | 50 | A |
| Diode pulsed current ²⁾ , $T_C=25\text{ °C}$ | $I_{F, pulse}$ | 200 | A |
| Power dissipation ³⁾ , $T_C=25\text{ °C}$ | P_D | 231 | W |
| Power dissipation ³⁾ , $T_C=100\text{ °C}$ | | 116 | W |
| Operation and storage temperature | T_{stg}, T_{vj} | -55 to 175 | °C |

Thermal Characteristics

| Parameter | Symbol | Value | Unit |
|---|-----------------|-------|------|
| IGBT thermal resistance, junction-case | $R_{\theta JC}$ | 0.65 | °C/W |
| Diode thermal resistance, junction-case | $R_{\theta JC}$ | 0.6 | °C/W |
| Thermal resistance, junction-ambient | $R_{\theta JA}$ | 40 | °C/W |

Electrical Characteristics at $T_{vj}=25\text{ °C}$ unless otherwise specified

| Parameter | Symbol | Min. | Typ. | Max. | Unit | Test condition |
|--------------------------------------|---------------|------|------|------|---------------|--|
| Collector-emitter breakdown voltage | $V_{(BR)CES}$ | 650 | | | V | $V_{GE}=0\text{ V}$, $I_C=0.5\text{ mA}$ |
| Collector-emitter saturation voltage | $V_{CE(sat)}$ | | 1.55 | 2.0 | V | $V_{GE}=15\text{ V}$, $I_C=50\text{ A}$ $T_{vj}=25\text{ °C}$ |
| | | | 1.89 | | V | $V_{GE}=15\text{ V}$, $I_C=50\text{ A}$, $T_{vj}=125\text{ °C}$ |
| | | | 2.12 | | V | $V_{GE}=15\text{ V}$, $I_C=50\text{ A}$, $T_{vj}=175\text{ °C}$ |
| Gate-emitter threshold voltage | $V_{GE(th)}$ | 3.5 | 4.0 | 4.5 | V | $V_{CE}=V_{GE}$, $I_C=0.5\text{ mA}$ |
| Diode forward voltage | V_F | | 1.35 | 1.55 | V | $V_{GE}=0\text{ V}$, $I_F=50\text{ A}$ $T_{vj}=25\text{ °C}$ |
| | | | 1.21 | | V | $V_{GE}=0\text{ V}$, $I_F=50\text{ A}$, $T_{vj}=125\text{ °C}$ |
| | | | 1.14 | | V | $V_{GE}=0\text{ V}$, $I_F=50\text{ A}$, $T_{vj}=175\text{ °C}$ |
| Gate-emitter leakage current | I_{GES} | | | 100 | nA | $V_{CE}=0\text{ V}$, $V_{GE}=20\text{ V}$ |
| Zero gate voltage collector current | I_{CES} | | | 10 | μA | $V_{CE}=650\text{ V}$, $V_{GE}=0\text{ V}$ |

Dynamic Characteristics

| Parameter | Symbol | Min. | Typ. | Max. | Unit | Test condition |
|------------------------------|--------------|------|------|------|------|--|
| Input capacitance | C_{ies} | | 5517 | | pF | $V_{GE}=0\text{ V}$, $V_{CE}=25\text{ V}$, $f=100\text{ kHz}$ |
| Output capacitance | C_{oes} | | 195 | | pF | |
| Reverse transfer capacitance | C_{res} | | 21 | | pF | |
| Turn-on delay time | $t_{d(on)}$ | | 31 | | ns | $V_{GE}=15\text{ V}$, $V_{CC}=400\text{ V}$, $R_G=10\ \Omega$, $I_C=50\text{ A}$ |
| Rise time | t_r | | 37 | | ns | |
| Turn-off delay time | $t_{d(off)}$ | | 130 | | ns | |
| Fall time | t_f | | 37 | | ns | |
| Turn-on energy | E_{on} | | 0.88 | | mJ | |
| Turn-off energy | E_{off} | | 0.51 | | mJ | |
| Turn-on delay time | $t_{d(on)}$ | | 30 | | ns | $V_{GE}=15\text{ V}$, $V_{CC}=400\text{ V}$, $R_G=10\ \Omega$, $I_C=25\text{ A}$ |
| Rise time | t_r | | 17 | | ns | |
| Turn-off delay time | $t_{d(off)}$ | | 142 | | ns | |
| Fall time | t_f | | 20 | | ns | |
| Turn-on energy | E_{on} | | 0.29 | | mJ | |
| Turn-off energy | E_{off} | | 0.17 | | mJ | |

Gate Charge Characteristics

| Parameter | Symbol | Min. | Typ. | Max. | Unit | Test condition |
|-----------------------|----------|------|------|------|------|--|
| Total gate charge | Q_g | | 112 | | nC | $V_{GE}=15\text{ V}$, $V_{CC}=520\text{ V}$, $I_C=50\text{ A}$ |
| Gate-emitter charge | Q_{ge} | | 36 | | nC | |
| Gate-collector charge | Q_{gc} | | 37 | | nC | |

Body Diode Characteristics

| Parameter | Symbol | Min. | Typ. | Max. | Unit | Test condition |
|-------------------------------------|-----------|------|------|------|---------------|--|
| Diode reverse recovery time | t_{rr} | | 114 | | ns | $V_R=400\text{ V}$, $I_F=50\text{ A}$, $di_F/dt=500\text{ A}/\mu\text{s}$ $T_{vj}=25\text{ }^\circ\text{C}$ |
| Diode reverse recovery charge | Q_{rr} | | 1.1 | | μC | |
| Diode peak reverse recovery current | I_{rrm} | | 16 | | A | |

Note

- 1) Calculated continuous current based on maximum allowable junction temperature.
- 2) Repetitive rating; pulse width limited by max. junction temperature.
- 3) P_d is based on max. junction temperature, using junction-case thermal resistance.

Electrical Characteristics Diagrams

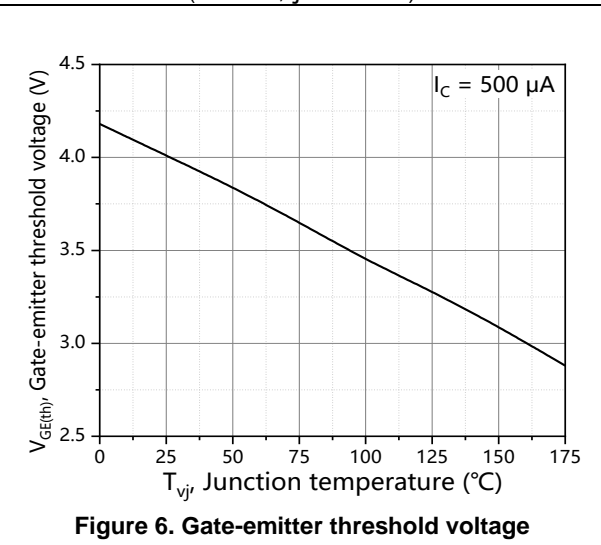
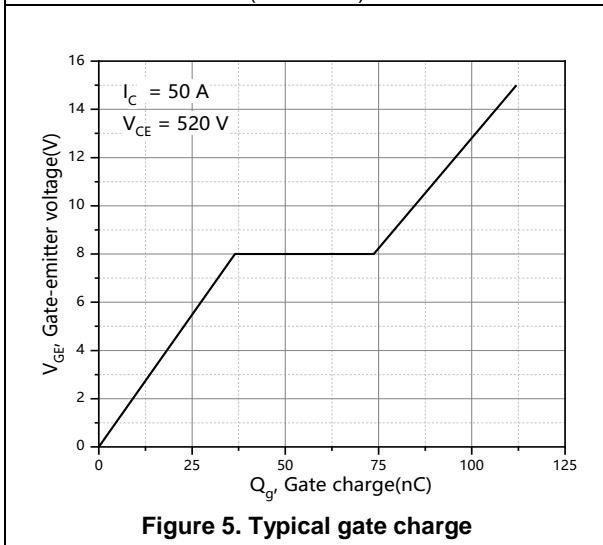
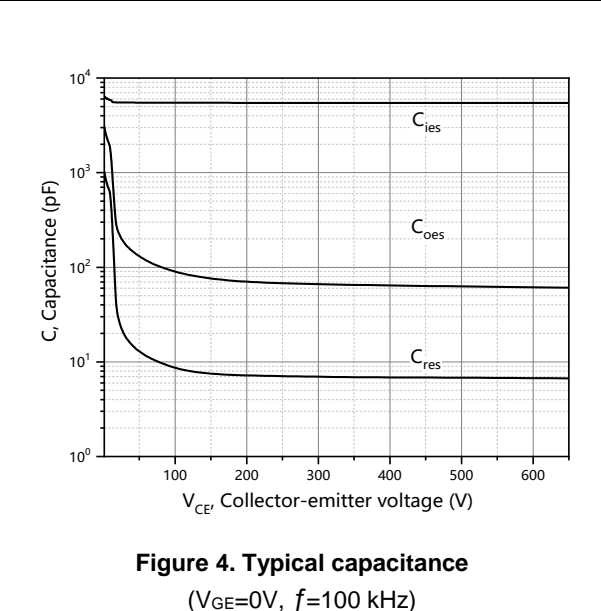
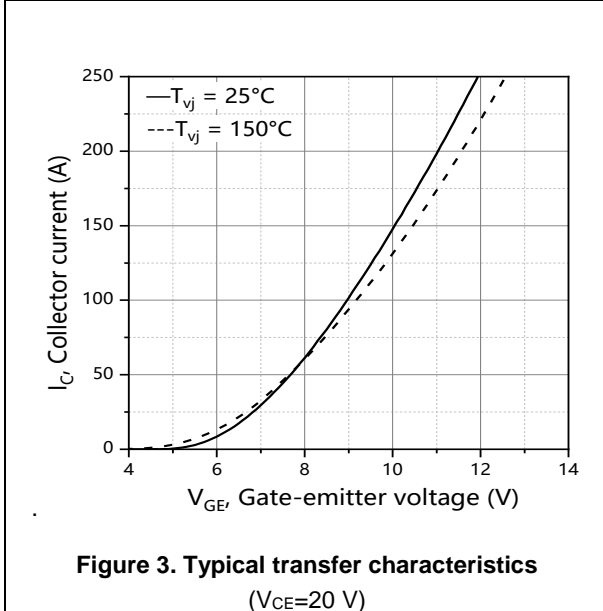
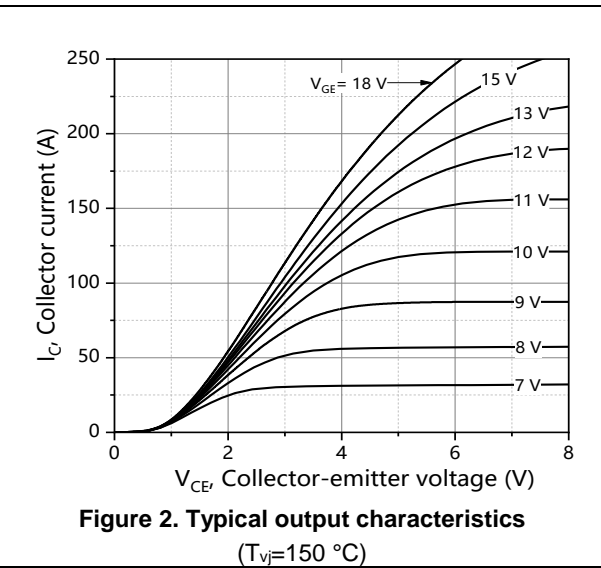
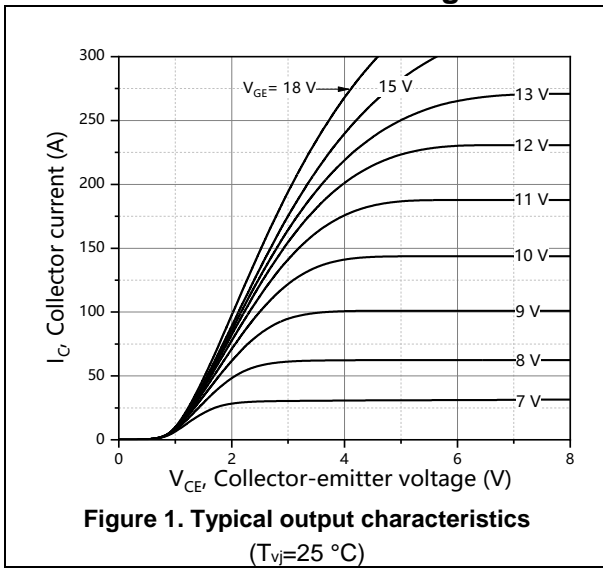

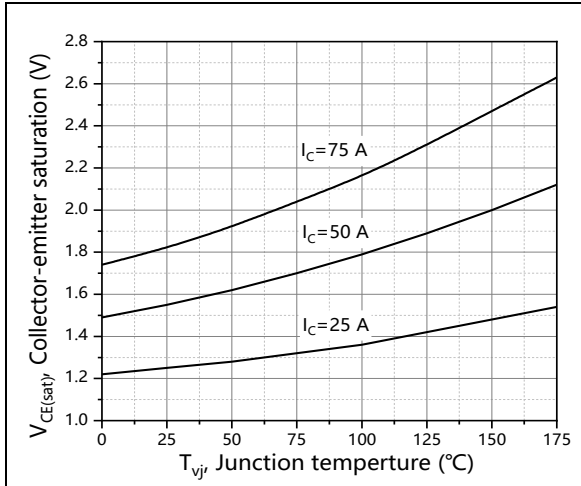

Figure 7. Typical collector-emitter voltage

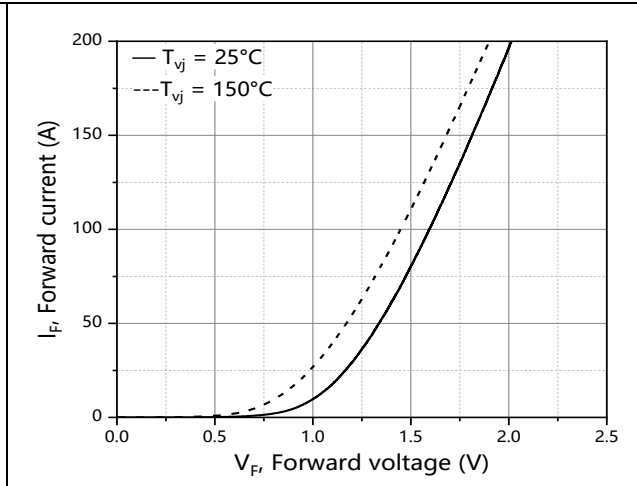

Figure 8. Forward characteristic of diode

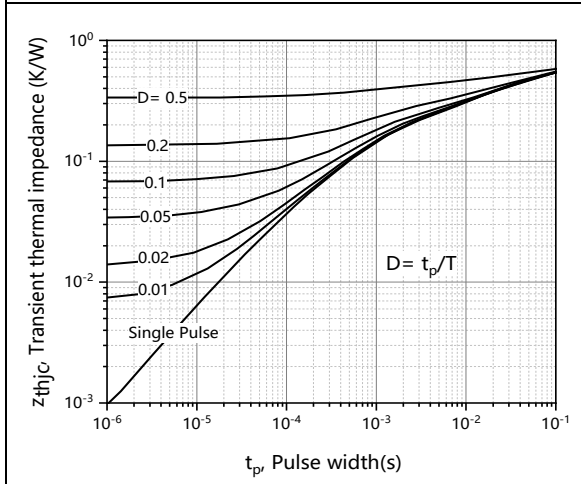

Figure 9. IGBT transient thermal impedance

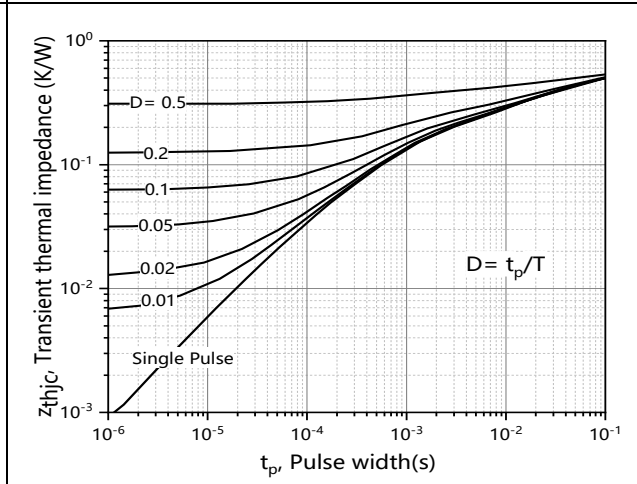

Figure 10. Diode transient thermal impedance

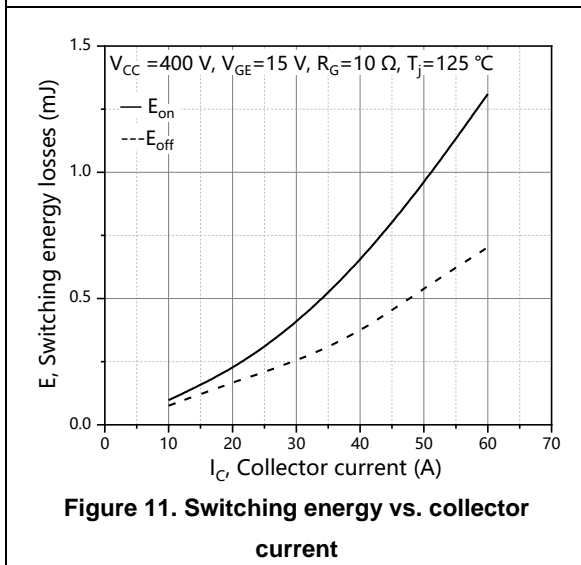
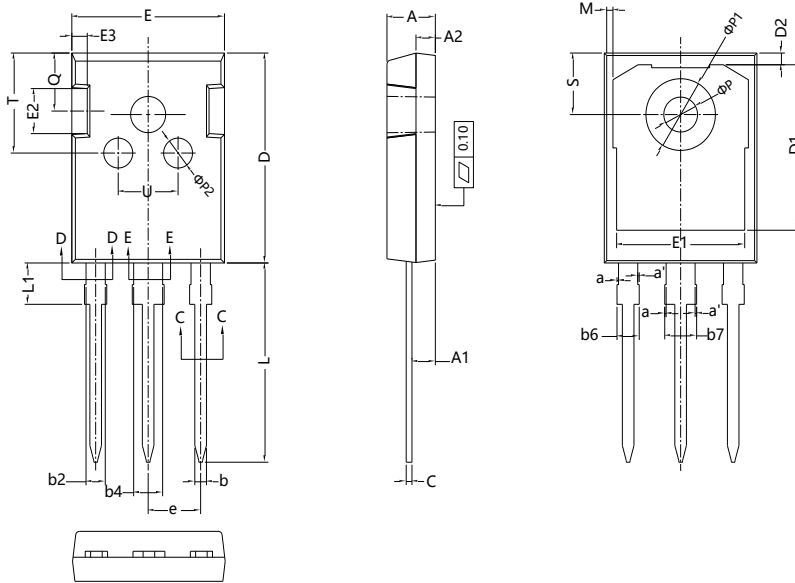

Figure 11. Switching energy vs. collector current

Package Information



| Symbol | mm | | |
|--------|-----------|-------|-------|
| | Min | Nom | Max |
| A | 4.90 | 5.00 | 5.10 |
| A1 | 2.31 | 2.41 | 2.51 |
| A2 | 1.90 | 2.00 | 2.10 |
| a | 0.00 | - | 0.15 |
| a' | 0.00 | - | 0.15 |
| b | 1.16 | - | 1.26 |
| b2 | 1.96 | - | 2.06 |
| b4 | 2.96 | - | 3.06 |
| b6 | - | - | 2.25 |
| b7 | - | - | 3.25 |
| c | 0.59 | - | 0.66 |
| D | 20.90 | 21.00 | 21.10 |
| D1 | 16.25 | 16.55 | 16.85 |
| D2 | 1.05 | 1.17 | 1.35 |
| E | 15.70 | 15.80 | 15.90 |
| E1 | 13.10 | 13.30 | 13.50 |
| E2 | 4.40 | 4.50 | 4.60 |
| E3 | 1.50 | 1.60 | 1.70 |
| e | 5.436 BSC | | |
| L | 19.80 | 19.92 | 20.10 |
| L1 | - | - | 4.30 |
| M | 0.35 | - | 0.95 |
| P | 3.40 | 3.50 | 3.60 |
| P1 | 7.00 | - | 7.40 |
| P2 | 2.40 | 2.5 | 2.6 |
| Q | 5.60 | - | 6.0 |
| S | 6.05 | 6.15 | 6.25 |
| T | 9.8 | - | 10.20 |
| U | 6.00 | - | 6.40 |

Version 1: TO247-J package outline dimension

Ordering Information

| Package Type | Units/ Tube | Tubes/ Inner Box | Units/ Inner Box | Inner Boxes/ Carton Box | Units/ Carton Box |
|--------------|-------------|------------------|------------------|-------------------------|-------------------|
| TO247-J | 30 | 20 | 600 | 4 | 2400 |

Product Information

| Product | Package | Pb Free | RoHS | Halogen Free |
|---------------|---------|---------|------|--------------|
| OST50N65HEV2F | TO247 | yes | yes | yes |

Legal Disclaimer

The information given in this document shall in no event be regarded as a guarantee of conditions or characteristics. With respect to any examples or hints given herein, any typical values stated herein and/or any information regarding the application of the device, Oriental Semiconductor hereby disclaims any and all warranties and liabilities of any kind, including without limitation, warranties of non-infringement of intellectual property rights of any third party.

For further information on technology, delivery terms and conditions and prices, please contact the Oriental Semiconductor sales representatives (www.orientalsemi.com).

© Oriental Semiconductor Co.,Ltd. All Rights Reserved 