

## General Description

OST15N65FRF uses advanced Oriental-Semi's patented Trident-Gate Bipolar Transistor (TGBT™) technology to provide extremely low  $V_{CE(sat)}$ , low gate charge, and excellent switching performance. This device is suitable for mid to high range switching frequency converters.

## Features

- Advanced TGBT™ technology
- Excellent conduction and switching loss
- Excellent stability and uniformity
- Fast and soft antiparallel diode



## Applications

- Induction converters
- Uninterruptible power supplies

## Key Performance Parameters

Parameter	Value	Unit
$V_{CES, min} @ 25\text{ }^{\circ}\text{C}$	650	V
Maximum junction temperature	175	$^{\circ}\text{C}$
$I_C, pulse$	45	A
$V_{CE(sat), typ} @ V_{GE}=15\text{ V}$	1.65	V
$Q_g$	73	nC

## Marking Information

Product Name	Package	Marking
OST15N65FRF	TO220F	OST15N65FR

## Package & Pin Information

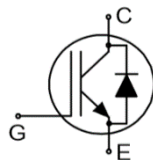

**Absolute Maximum Ratings** at  $T_{vj}=25\text{ °C}$  unless otherwise noted

Parameter	Symbol	Value	Unit
Collector emitter voltage	$V_{CES}$	650	V
Gate emitter voltage	$V_{GES}$	$\pm 20$	V
Transient gate emitter voltage, $T_P \leq 10\ \mu s$ , $D < 0.01$		$\pm 30$	V
Continuous collector current <sup>1)</sup> , $T_C = 25\text{ °C}$	$I_C$	30	A
Continuous collector current <sup>1)</sup> , $T_C = 100\text{ °C}$		15	A
Pulsed collector current <sup>2)</sup> , $T_C = 25\text{ °C}$	$I_{C, pulse}$	45	A
Diode forward current <sup>1)</sup> , $T_C = 25\text{ °C}$	$I_F$	30	A
Diode forward current <sup>1)</sup> , $T_C = 100\text{ °C}$		15	A
Diode pulsed current <sup>2)</sup> , $T_C = 25\text{ °C}$	$I_{F, pulse}$	45	A
Power dissipation <sup>3)</sup> , $T_C = 25\text{ °C}$	$P_D$	35	W
Power dissipation <sup>3)</sup> , $T_C = 100\text{ °C}$		17	W
Operation and storage temperature	$T_{stg}, T_{vj}$	-55 to 175	$^{\circ}\text{C}$
Short circuit withstand time $V_{GE} = 15\text{ V}$ , $V_{CC} \leq 400\text{ V}$ Allowed number of short circuits < 1000 Time between short circuits: $\geq 1.0\text{ S}$ $T_{vj} = 150\text{ °C}$	$t_{sc}$	10	$\mu s$

**Thermal Characteristics**

Parameter	Symbol	Value	Unit
IGBT thermal resistance, junction-case	$R_{\theta JC}$	4.3	$^{\circ}\text{C/W}$
Diode thermal resistance, junction-case	$R_{\theta JC}$	4.3	$^{\circ}\text{C/W}$
Thermal resistance, junction-ambient	$R_{\theta JA}$	65	$^{\circ}\text{C/W}$

**Electrical Characteristics** at  $T_{vj}=25\text{ °C}$  unless otherwise specified

Parameter	Symbol	Min.	Typ.	Max.	Unit	Test condition
Collector-emitter breakdown voltage	$V_{(BR)CES}$	650			V	$V_{GE}=0\text{ V}$ , $I_C=0.5\text{ mA}$
Collector-emitter saturation voltage	$V_{CE(sat)}$		1.65	2.0	V	$V_{GE}=15\text{ V}$ , $I_C=15\text{ A}$ $T_{vj}=25\text{ °C}$
			1.8		V	$V_{GE}=15\text{ V}$ , $I_C=15\text{ A}$ , $T_{vj}=125\text{ °C}$
			1.9			$V_{GE}=15\text{ V}$ , $I_C=15\text{ A}$ , $T_{vj}=175\text{ °C}$
Gate-emitter threshold voltage	$V_{GE(th)}$	4.4	5.2	6.0	V	$V_{CE}=V_{GE}$ , $I_D=0.5\text{ mA}$
Diode forward voltage	$V_F$		1.65	2.0	V	$V_{GE}=0\text{ V}$ , $I_F=15\text{ A}$ $T_{vj}=25\text{ °C}$
			1.8			$V_{GE}=0\text{ V}$ , $I_F=15\text{ A}$ , $T_{vj}=125\text{ °C}$
			1.9			$V_{GE}=0\text{ V}$ , $I_F=15\text{ A}$ , $T_{vj}=175\text{ °C}$
Gate-emitter leakage current	$I_{GES}$			100	nA	$V_{CE}=0\text{ V}$ , $V_{GE}=20\text{ V}$
Zero gate voltage collector current	$I_{CES}$			10	$\mu\text{A}$	$V_{CE}=650\text{ V}$ , $V_{GE}=0\text{ V}$

### Dynamic Characteristics

Parameter	Symbol	Min.	Typ.	Max.	Unit	Test condition
Input capacitance	$C_{ies}$		2015		pF	$V_{GE}=0\text{ V}$ , $V_{CE}=25\text{ V}$ , $f=100\text{ kHz}$
Output capacitance	$C_{oes}$		80		pF	
Reverse transfer capacitance	$C_{res}$		41		pF	
Turn-on delay time	$t_{d(on)}$		50		ns	$V_{GE}=15\text{ V}$ , $V_{CC}=400\text{ V}$ , $R_G=10\ \Omega$ , $I_C=15\text{ A}$
Rise time	$t_r$		36		ns	
Turn-off delay time	$t_{d(off)}$		143		ns	
Fall time	$t_f$		94		ns	
Turn-on energy	$E_{on}$		0.62		mJ	
Turn-off energy	$E_{off}$		0.11		mJ	

### Gate Charge Characteristics

Parameter	Symbol	Min.	Typ.	Max.	Unit	Test condition
Total gate charge	$Q_g$		73		nC	$V_{GE}=15\text{ V}$ , $V_{CC}=520\text{ V}$ , $I_C=15\text{ A}$
Gate-emitter charge	$Q_{ge}$		22		nC	
Gate-collector charge	$Q_{gc}$		36		nC	

### Body Diode Characteristics

Parameter	Symbol	Min.	Typ.	Max.	Unit	Test condition
Diode reverse recovery time	$t_{rr}$		94		ns	$V_R=400\text{ V}$ , $I_F=15\text{ A}$ , $di_F/dt=500\text{ A}/\mu\text{s}$ $T_{vj}=25\text{ }^\circ\text{C}$
Diode reverse recovery charge	$Q_{rr}$		1.2		$\mu\text{C}$	
Diode peak reverse recovery current	$I_{rrm}$		21.7		A	

### Note

- 1) Calculated continuous current based on maximum allowable junction temperature.
- 2) Repetitive rating; pulse width limited by max. junction temperature.
- 3)  $P_d$  is based on max. junction temperature, using junction-case thermal resistance.

**Electrical Characteristics Diagrams**

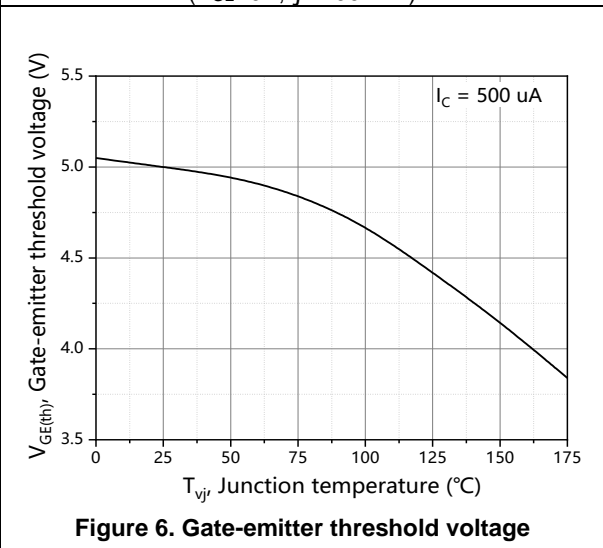
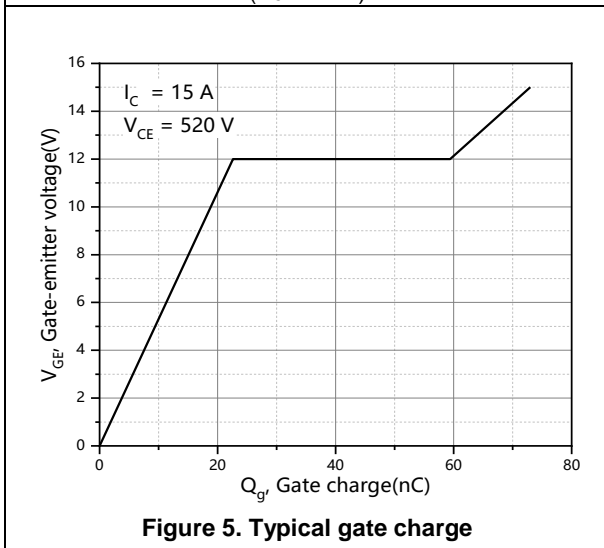
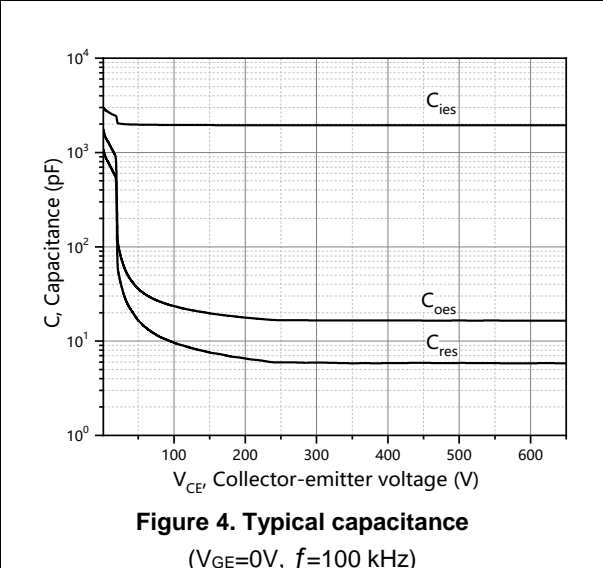
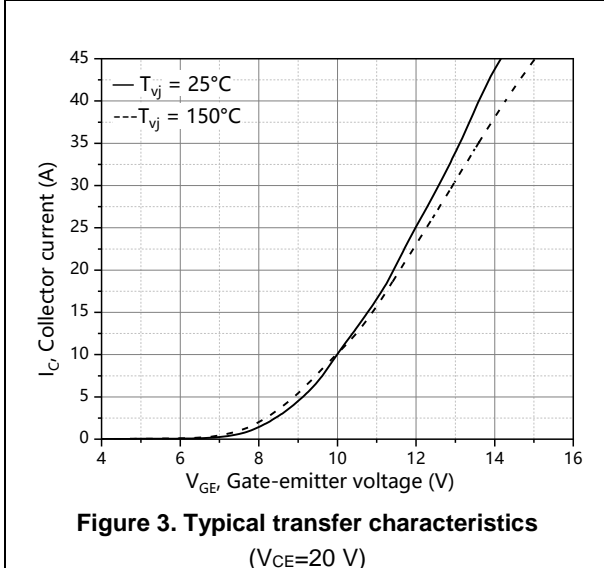
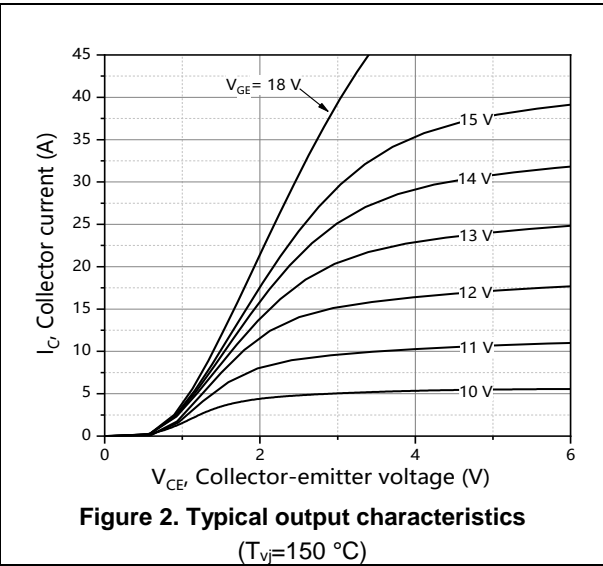
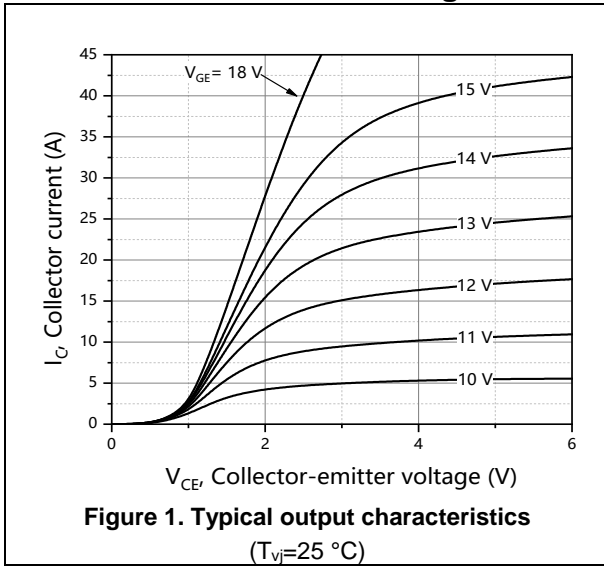

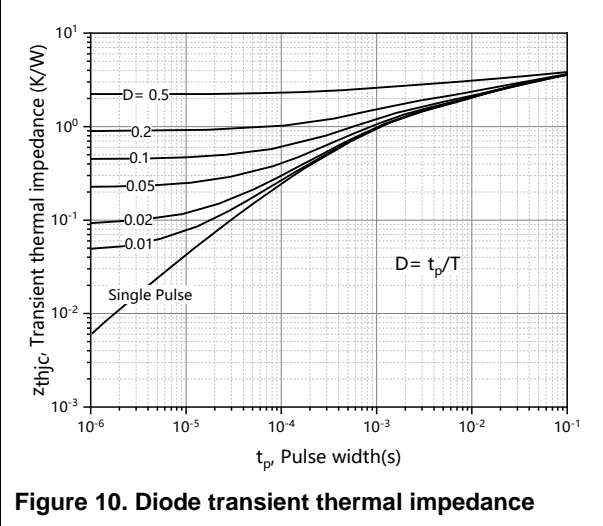
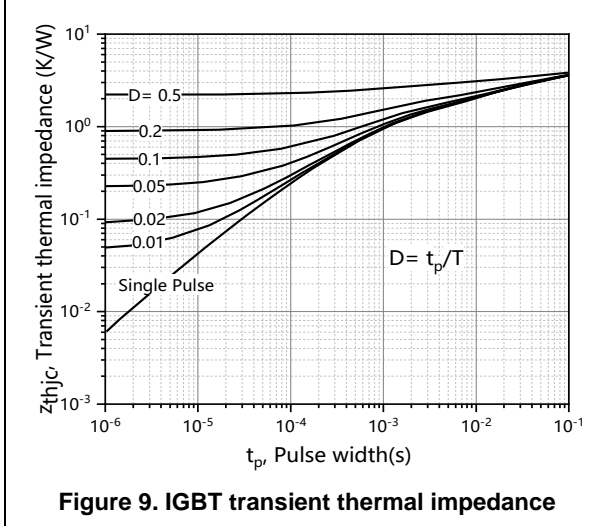
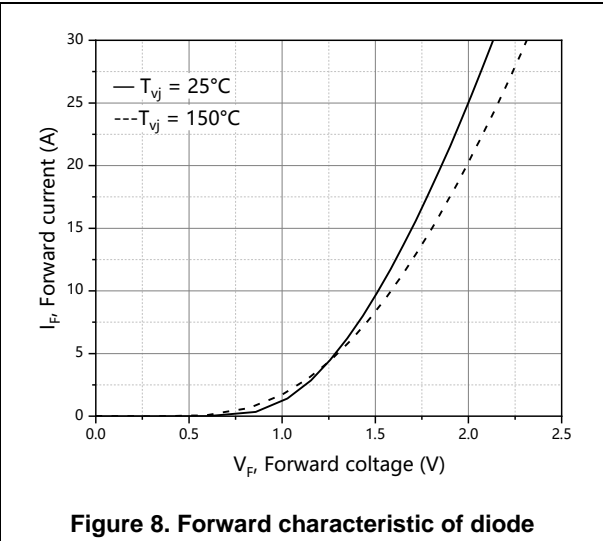
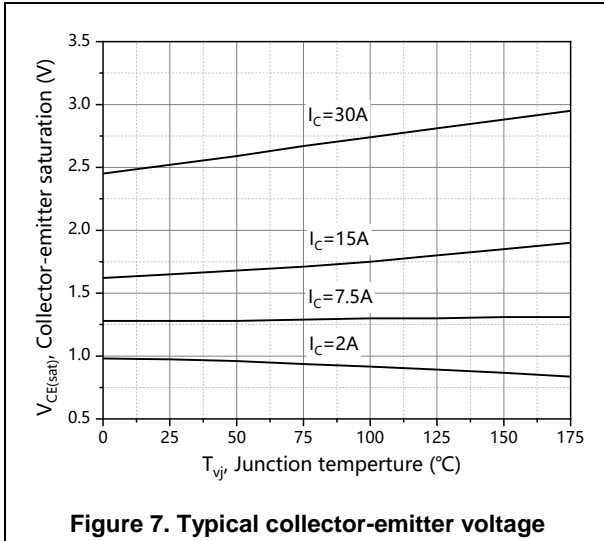

**Package Information**

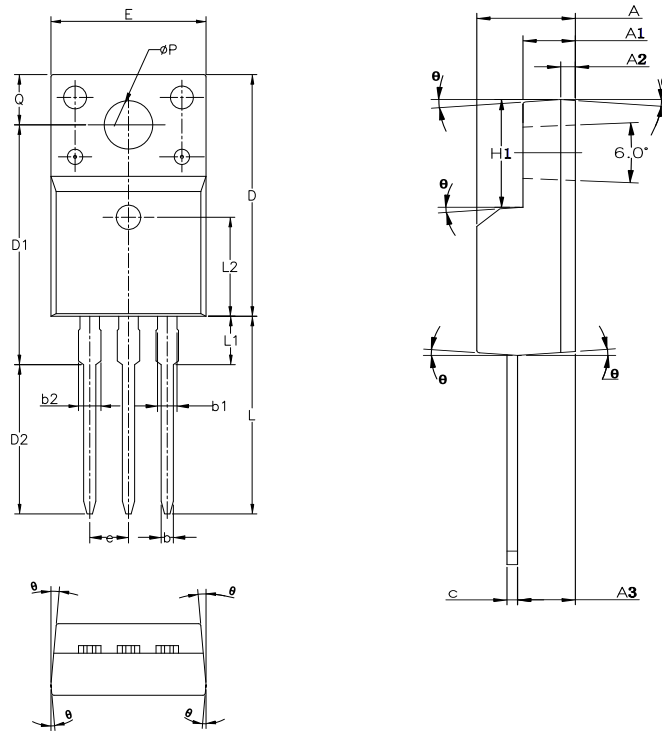

Symbol	mm		
	Min	Nom	Max
A	4.50	4.70	4.83
A1	2.34	2.54	2.74
A2	0.70 REF		
A3	2.56	2.76	2.93
b	0.70	-	0.90
b1	1.18	-	1.38
b2	-	-	1.47
c	0.45	0.50	0.60
D	15.67	15.87	16.07
D1	15.55	15.75	15.95
D2	9.60	9.80	10.00
E	9.96	10.16	10.36
e	2.54 BSC		
H1	6.48	6.68	6.88
L	12.68	12.98	13.28
L1	-	-	3.50
L2	6.50 REF		
phi P	3.08	3.18	3.28
Q	3.20	-	3.40
theta	1°	3°	5°

Version 1: TO220F-J package outline dimension

## Ordering Information

Package Type	Units/ Tube	Tubes/ Inner Box	Units/ Inner Box	Inner Boxes/ Carton Box	Units/ Carton Box
TO220F-J	50	20	1000	5	5000

## Product Information

Product	Package	Pb Free	RoHS	Halogen Free
OST15N65FRF	TO220F	yes	yes	yes

## Legal Disclaimer

The information given in this document shall in no event be regarded as a guarantee of conditions or characteristics. With respect to any examples or hints given herein, any typical values stated herein and/or any information regarding the application of the device, Oriental Semiconductor hereby disclaims any and all warranties and liabilities of any kind, including without limitation, warranties of non-infringement of intellectual property rights of any third party.

For further information on technology, delivery terms and conditions and prices, please contact the Oriental Semiconductor sales representatives ([www.orientalsemi.com](http://www.orientalsemi.com)).

© Oriental Semiconductor Co.,Ltd. All Rights Reserved 